

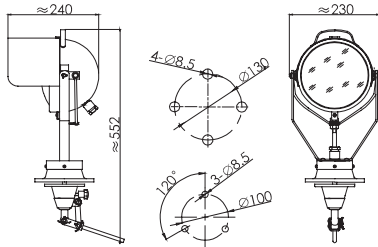

TG16A

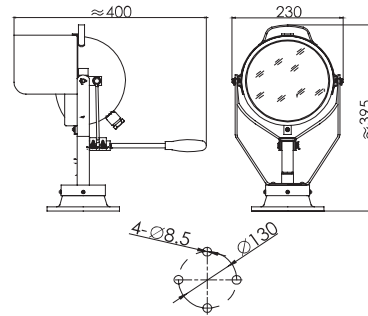

TG16B



■ 适用范围：

该灯具适用于中、小型船舶夜间航行、厂矿、码头等处检修和警戒照明之用。

■ 产品特性：

1. 体积小、操作灵活。
2. 灯体为钢质外壳，铸铁底座。
3. 灯具可作水平旋转 180°，俯仰 45° 调节。
4. 灯具采用反射灯泡，光效高。
5. 电缆外径 $\varnothing 10 \sim \varnothing 12\text{mm}$ 。

■ 采用标准及产品认证：

1. 符合《钢质海船入级规范》。
2. 符合 GB 7000.7 《投光灯具安全要求》。
3. 符合 GD01 《电气电子产品型式认可试验指南》。

■ The scope of application:

This product is designed to use for illumination for service or alarm lighting at small and medium size when navigate at night, factories and mines, wharf etc.

■ Products feature:

1. Small volume and flexible of operation.
2. The body of light is composed of steel shell and cast iron base.
3. The body of light can be rotated 180 degree in horizontal and adjusted 45 degree in pitch.
4. Reflector bulbs with high lighting efficiency.
5. The cable outside diameter is $\varnothing 10 \sim \varnothing 12\text{mm}$.

■ Adopt standard and products certification:

1. Conform to RULES FOR CLASSIFICATION OF SEA-GOING STEEL SHIPS.
2. Conform to GB7000.7 of SAFETY REQUIREMENTS FOR FLOOD LIGHT.
3. Conform to GD01 of GUIDELINES FOR TYPE APPROVAL TEST OF ELECTRIC AND ELECTRONIC PRODUCTS.

型号 Type	功率 (W) Power	电压 (V) Voltage	光源 Illuminant	重量 (Kg) Weight	灯座 Lamp holder	光通量 (Lm) Luminous flux	防护等级 Protection class
TG16A	100/200	12/24	反射灯泡	6.2	专用 For special use	1600	IP45
TG16B			Reflecting bulbs	4.4			